

## Modular Cooking Range Line thermaline 80 - 4 Zone Electric Solid Top on Oven, 1 Side H=700

ITEM # \_\_\_\_\_

MODEL # \_\_\_\_\_

NAME # \_\_\_\_\_

SIS # \_\_\_\_\_

AIA # \_\_\_\_\_



**588411 (MALLEAH8AO)** Electric Solid Top, 4 zones, one-side operated, on Oven

### Short Form Specification

#### Item No.

Unit constructed according to DIN 18860\_2 with 20 mm drop nose top. Internal frame for heavy duty sturdiness in stainless steel. 2 mm top in 1.4301 (AISI 304). Flat surface construction, easily cleanable. THERMODUL connection system enables seamless worktop when units are connected and avoids soil penetrating. Solid top made of smooth, pore-free, steel. 4 independently controlled heating zones with 2 electronic sensors per zone for temperature surface control and 8 power levels. Rapid plate heat up, continuously ready to use. Overheat protection switches off the supply in case of overheating. Standby function saves energy and quickly recovers maximum power. Metal knobs with embedded hygienic silicon "soft" grip enable easier handling and cleaning. Electric static oven base with 40 mm thick oven door and ribbed enamelled steel base plate. Constructed according to 1.4301 (AISI 304). Oven chamber with 2 levels of runners for 2/1 GN shelves to enable simultaneous and faster cooking. Heavy duty thermostat with temperature range up to 300°C, electronic sensor for precise temperature control and manual humidity control in the cooking chamber. Upper heating element can also be used for grilling, with or without ventilating mode. Flat surface construction, easily cleanable. Overheat protection switches off the supply in case of overheating. Standby function saves energy and quickly recovers maximum power. Metal knobs and oven handles ergonomically designed with embedded hygienic silicon "soft" grip enable easier handling and cleaning. IPX5 water resistance certification.

### Main Features

- 4 heating zones independently controlled.
- Rapid heat up of the plate and continuously ready for use.
- Overheat protection: a temperature sensor switches off the supply in case of overheating.
- Pans can easily be moved from one area to another without lifting.
- Wide rounded cleaning zone around the plates for easier cleaning.
- IPX5 water resistance certification.
- All major components may be easily accessed from the front.
- THERMODUL connection system creates a seamless work top when units are connected to each other thus avoiding soil penetrating vital components and facilitating the removal of units in case of replacement or service.
- Metal knobs with embedded hygienic silicon "soft" grip for easier handling and cleaning. The special design of the controls prevent infiltration of liquids or soil into vital components.
- Cooking plate and base joint profile guarantee against soil infiltration.
- Two electronic sensors per zone to control surface temperature and to protect cooking plate from overheating.
- 8 power levels.
- Solid top cooking surface made of 20 mm thick steel, DIN 1.7335, smooth pore-free and easy to clean.
- Large visible digital display manufactured in tempered glass to resist heat and chemicals, showing temperatures or power settings. The display also shows on/off status of the appliance and on/off status of the heating elements.
- 40 mm thick oven door for heat insulation.
- Handles are ergonomically designed with silicon "soft" grip for easy handling and cleaning.
- Oven chamber to have 2 levels of runners to accommodate 2/1 GN trays and ribbed enamelled steel base plate.
- Heavy duty thermostat with temperature range up to 300°C.
- The upper heating element of the oven can also be used for grilling.
- Manual control of humidity in cooking chamber.
- Electronic sensor for precise temperature control.
- Unit constructed according to DIN 18860\_2 with 70 mm recessed plinth.
- Oven temperature up to 300 °C

### Construction

- 2 mm top in 1.4301 (AISI 304).
- Flat surface construction with minimal hidden areas to easily clean all surfaces
- Unit constructed according to DIN 18860\_2 with 20 mm drop nose top.
- Unit constructed according to DIN 18860\_2

APPROVAL: \_\_\_\_\_

with 20 mm drop nose top and 70 mm recessed plinth.

- Internal frame for heavy duty sturdiness in stainless steel.

### Sustainability



- Standby function for energy saving and fast recovery of maximum power.

### Included Accessories

- 1 of Grid, chromium plated, for ovens PNC 910652 2/1 GN

### Optional Accessories

- Baking sheet 2/1 GN for ovens PNC 910651
- Bottom steel plate 2/1 GN for fire clay plate 800&900 with baking oven PNC 910655
- Fire clay plate 2/1 GN for ovens PNC 910656
- Connecting rail kit, 800mm PNC 912500
- Stainless steel side panel, 800x700mm, freestanding PNC 912509
- Portioning shelf, 800mm width PNC 912526
- Portioning shelf, 800mm width PNC 912556
- Folding shelf, 300x800mm PNC 912577
- Folding shelf, 400x800mm PNC 912578
- Fixed side shelf, 200x800mm PNC 912583
- Fixed side shelf, 300x800mm PNC 912584
- Fixed side shelf, 400x800mm PNC 912585
- Stainless steel front kicking strip, 800mm width PNC 912634
- Stainless steel side kicking strip left and right, freestanding, 800mm width PNC 912655
- Stainless steel side kicking strip left and right, back-to-back, 1610mm width PNC 912661
- Stainless steel plinth, freestanding, 800mm width PNC 912863
- Connecting rail kit: modular 80 (on the left) to ProThermetic tilting (on the right), ProThermetic stationary (on the left) to ProThermetic (on the right) PNC 912971
- Connecting rail kit: modular 80 (on the right) to ProThermetic tilting (on the left), ProThermetic stationary (on the right) to ProThermetic (on the left) PNC 912972
- Endrail kit, flush-fitting, left PNC 913109
- Endrail kit, flush-fitting, right PNC 913110
- Endrail kit (12.5mm) for thermaline 80 units, left PNC 913200
- Endrail kit (12.5mm) for thermaline 80 units, right PNC 913201
- Stainless steel side panel, left, H=700 PNC 913214
- Stainless steel side panel, right, H=700 PNC 913215
- T-connection rail for back-to-back installations without backsplash PNC 913227
- Insert profile D=800mm PNC 913230
- Energy optimizer kit 32A - factory fitted PNC 913247

- Endrail kit, (12.5mm), for back-to-back installation, left PNC 913249
- Endrail kit, (12.5mm), for back-to-back installation, right PNC 913250
- Endrail kit, flush-fitting, for back-to-back installation, left PNC 913253
- Endrail kit, flush-fitting, for back-to-back installation, right PNC 913254
- Side reinforced panel only in combination with side shelf, for freestanding units PNC 913258
- Side reinforced panel only in combination with side shelf, for back-to-back installations, left PNC 913271
- Side reinforced panel only in combination with side shelf, for back-to-back installation, right PNC 913272
- Filter W=800mm PNC 913665
- Stainless steel dividing panel, 800x700mm, (it should only be used between Electrolux Professional thermaline Modular 80 and thermaline C80) PNC 913668
- Stainless steel side panel, 800x700mm, flush-fitting (it should only be used against the wall, against a niche and in between Electrolux Professional thermaline and ProThermetic appliances and external appliances - provided that these have at least the same dimensions) PNC 913684

Front

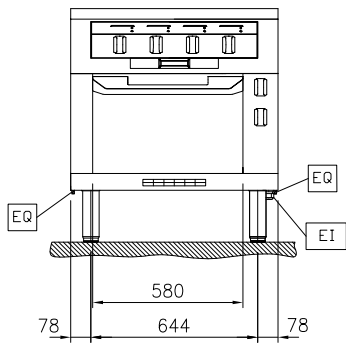

Side

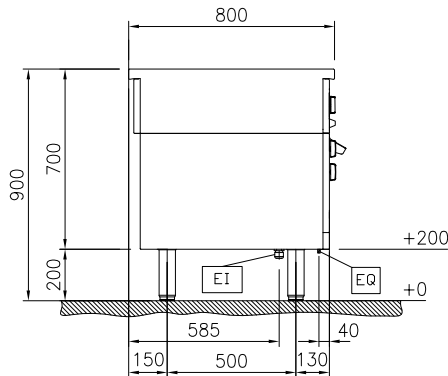

EI = Electrical inlet (power)  
 EQ = Equipotential screw

Top

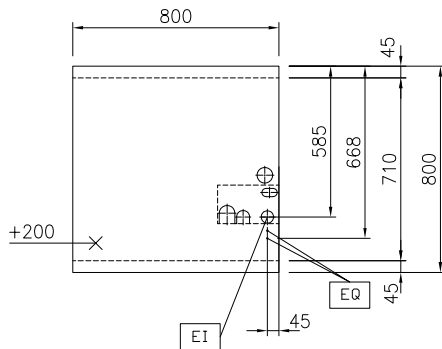

## Electric

Supply voltage:

588411 (MALLEAH8AO) 400 V/3N ph/50/60 Hz

Electrical power max.:

17.3 kW

## Key Information:

Configuration: On Oven, One-Side Operated

Front Plates Power: 3 - 3 kW

Back Plates Power: 3 - 3 kW

Solid top usable surface (width): 670 mm

Solid top usable surface (depth): 650 mm

External dimensions, Width: 800 mm

External dimensions, Depth: 800 mm

External dimensions, Height: 700 mm

Net weight: 208 kg

## Sustainability

Current consumption: 31.7 Amps